

GZFI8186.0

Key #	Part Number	Description	Qty.
1	GZ5629	FRAME	1
2	GZ5611	TOWER	1
3	GZ3453	TOWER CAP	1
4	GZ1566	LONG PANEL FRAME	1
5	GZ30348	LONG PANEL	1
6	GZ1567	SHORT PANEL FRAME	1
7	GZ30347	SHORT PANEL	1
8	GZ2342	PIVOT BRACKET	1
9	171178	ROUND ENDCAP	2
10	GZ5633	PIVOT FRAME	1
11	GZ9444	LEFT BASE PANEL	1
12	GZ1867	PEDAL SPRING	1
13	GZ3248-10	WEIGHT GUIDE	2
14	GZ1504	LONG TRIM	2
15	GZ9443	RIGHT BASE PANEL	1
16	GZ5108-65	KNEE PAD	2
17	GZ31023	REAR BASE PANEL	1
18	GZ30598	WEIGHT	14
19	GZ4392	TOP WEIGHT	1
20	GZ5485	WEIGHT ROD	1
21	GZ1839	CABLE END AXLE	1
22	GZ5108-11	SEAT	1
23	GZ1527	1/4" SPIDER NUT	2
24	GZ5108-69	ARM PAD	2
25	225669	OVAL OUTER CAP	2
26	GZ30828	REAR ACCESS PANEL	1
27	GZ1751	ACCESS PANEL GASKET	1
28	GZ30218	1/4" X 1" BLACK COUNTERSINK SCREW	10
29	GZ30218	ANCHOR STRAP	1
30	GZ1486	BASE FOOT	4
31	GZ5631	FOOT PEDAL	1
32	GZ1879	1/4" ACORN NUT	2
33	142324	RUBBER BUMPER	3
34	GZ1868	PEDAL ROD	2
35	GZ1678	WEIGHT BUMPER	2
36	GZ1431	ROD WASHER	1
37	GZ1391-01	WEIGHT INSERT	29
38	GZ1020	GUIDE BUSHING	2
39	GZ1673	5/16" SET SCREW	4
40	GZ1500	WEIGHT PIN	1
41	GZ1419	STAR WASHER	1
42	GZ1418	ROD NUT	1
43	GZ1353	COUPLER COVER	1
44	GZ1038-06	1/4" X 1" COUNTERSINK SCREW	15
45	GZ1735	1/4" CAGE NUT	6
46	CC1296	3/8" X 2 1/2" BUTTON SCREW	4
47	213126	PAD CAP	2
48	GZ1063	ROD END	2
49	GZ1152	3/8" X 1" BUTTON BOLT BOLT	4
50	GZ5020-51	CABLE	1
51	GZ1003-08	PULLEY	6
52	GZ3102	CABLE GUARD	4
53	GZ3516	TOWER COVER	1
54	GZ1855	STEEL PIN WASHER	1
55	GZ1013-18	1/4" X 3/4" SCREW	4
56	GZ1517	TOWER FOOT	4
57	GZ1021-01	RIVET	4
58	GZ1085	GUIDE ROD WASHER	4
59	GZ1084	GUIDE ROD NUT	4
60	GZ5108-67	BACKREST	1

61	103762	#8 NUT	2
62	GZ1009-03	1/2" X 1 1/4" SCREW	2
63	GZ1872	3/8" X 1 1/2" SHOULDER SCREW	2
64	GZ1706	PLASTIC BEARING	5
65	012082	5/16" NYLON LOCKNUT	2
66	GZ1100	SMALL RUBBER BUMPER	1
67	GZ1155-01	5/16" X 5/8" SCREW	1
68	GZ1430	WINGNUT	2
69	GZ1012-07	3/8" X 1/2" BUTTON BOLT	16
70	GZ1011-01	1" BEARING	4
71	174796	1/4" X 1" BUTTON BOLT	2
72	GZ1837	MAIN AXLE	1
73	GZ1708	SMALL NYLON WASHER	1
74	GZ1707	3/8" X 3/8" SHOULDER BOLT	1
75	GZ31077	LIFT PIVOT BRACKET	1
76	GZ1013-04	3/8" X 2" BOLT	6
77	GZ1007	3/8" NYLON LOCKNUT	10
78	GZ1069	SERRATED WASHER	2
79	GZ1013-12	3/8" X 1 1/4" BOLT	4
80	GZ5642	PIN LIFT HOUSING	1
81	GZ1715	LARGE BRASS BUSHING	2
82	GZ5640	PIN LIFT BRACKET	1
83	GZ7330	FOOT PEDAL COVER	1
84	GZ1881	9/16" RETAINER RING	1
85	GZ1856	NYLON PIN WASHER	1
86	GZ1677	PIN SPRING	1
87	GZ1097	1/4" ROLL PIN	1
88	GZ1052	1" NYLON WASHER	3
89	GZ1018-07	1" RETAINER RING	2
90	GZ1854	CABLE END WASHER	2
91	GZ1853	SMALL BRASS BUSHING	2
92	GZ5632	CAM	1
93	GZ1875	ADJUSTMENT PIN	1
94	GZ1083	3/8" FINE THREAD NUT	2
95	GZ5124-13	WEAR COVER	1
96	121671	#8 X 3/4" SCREW	2
97	013300	#8 X 3/4" SELF-TAPPING SCREW	4
98	GZ1679	3/4" WASHER	2
99	GZ3007	WEIGHT SPACERS	2
	0	NON-ILLUSTRATED PARTS	4
		WHAT PART IS NEEDED?	
#	GZ7482	USER'S MANUAL	1
#	GZ7482FR	USER'S MANUAL	1
#	GZ7482G	USER'S MANUAL	1
#	GZ7482IT	USER'S MANUAL	1
#	GZ7482SP	USER'S MANUAL	1
		WHAT PART IS NEEDED?	
#	GZ7495	TECH SHEET	1
#	GZ7003	DECAL, WARNING	1
#	GZ7003FR	DECAL, WARNING	1
#	GZ7003G	DECAL, WARNING	1
#	GZ7003IT	DECAL, WARNING	1
#	GZ7003SP	DECAL, WARNING	1
		WHAT PART IS NEEDED?	
#	GZ7026	DECAL, SELECTOR PIN	1
#	GZ7026FR	DECAL, SELECTOR PIN	1
#	GZ7026G	DECAL, SELECTOR PIN	1
#	GZ7026IT	DECAL, SELECTOR PIN	1
#	GZ7026SP	DECAL, SELECTOR PIN	1
		WHAT PART IS NEEDED?	
#	GZ7005	DECAL, MOVING PARTS	1
#	GZ7005FR	DECAL, MOVING PARTS	1

#	GZ7005G	DECAL, MOVING PARTS	1
#	GZ7005IT	DECAL, MOVING PARTS	1
#	GZ7005SP	DECAL, MOVING PARTS	1

EXPLODED DRAWING—Model No. GZFI8186.0

R0607A

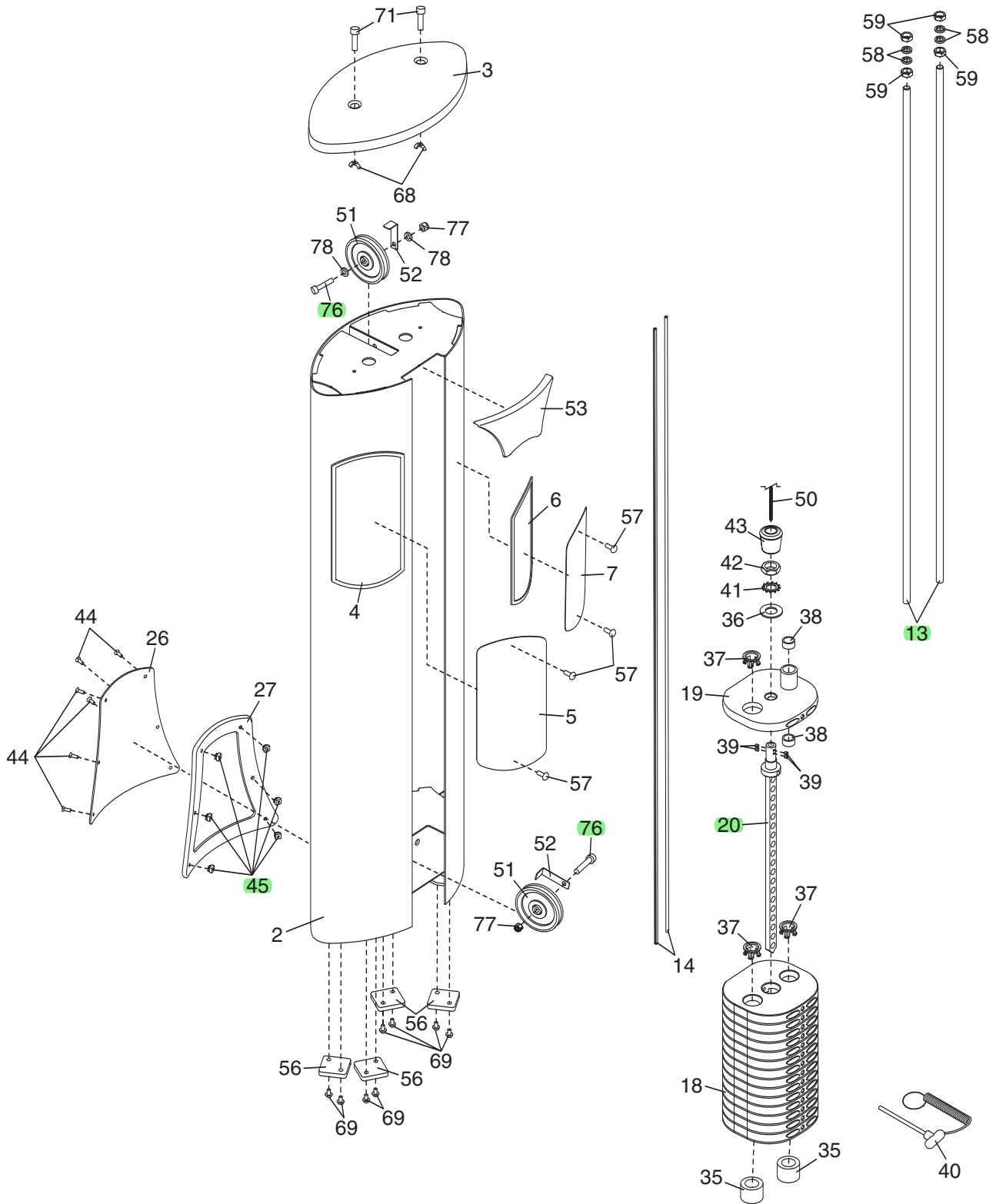

EXPLODED DRAWING—Model No. GZFI8186.0

R0607A

